

# Submersible Pressure Transmitter for Level Measurement

## Model LS-10, standard version

## Model LH-10, High Performance

WIKA Data Sheet PE 81.09



### Applications

- Areas of application are e. g. hydrostatic level measurement in tanks, rivers, drinking water manholes, bore holes and waste water plants.

### Special Features

- Pressure ranges from 0 ... 1 mH<sub>2</sub>O to 0 ... 250 mH<sub>2</sub>O
- Temperature measurement with integrated Pt 100-element, 4-wire
- Surge protection (lightning protection)
- Maximum tensile strength of the cable 1000 N
- For aggressive media FEP-cable

### Description

#### Simple measuring tasks

The level probe model LS-10 has been designed for simple, inexpensive level measurements with values you can count on. The output signal is 4 ... 20 mA with an accuracy of 0.5 %. The level probe can be operated in water up to a maximum of 100 m depth with an ingress protection of IP 68.

#### Special demands

With an accuracy better than 0.25 %, the High Performance Level Probe model LH-10 also offers several special options such as temperature measurement, lightning protection and special output signals.

It provides a signal output of 0.5 ... 4.5 V, 3-wire with a current consumption of approx. 2 mA only. For a mains independent service in the field, with batteries, the level probe can be manufactured to operate with a supply voltage of 5 VDC.



Fig. left Level Probe LS-10

Fig. center Level Probe LH-10

Fig. right Level Probe LH-10 in Hastelloy

The maximum immersion depth of the LH-10 into water is 300 m with an ingress protection of IP 68.

An important advantage of this level transmitter is the longitudinal water resistance, supplied as standard, which guarantees that liquid cannot get into the transmitter even if the cable is damaged. In the case of cable damage, the transmitter will remain completely functional and only the cable needs to be exchanged.

Both probes offer a hermetically sealed, durable stainless steel case.

For hydrostatic pressure measurement the pressure compensation towards the atmosphere is done via the internally vented cable.

# Specifications

# Model LS-10 / LH-10

Pressure ranges															
» LS-10 / {LH-10 with FEP cable}	bar <sup>1)</sup>	0.25	0.4	0.6	1	1.6	2.5	4	6	10					
Over pressure safety	bar <sup>1)</sup>	2	2	4	5	10	10	10	10	10					
Burst pressure	bar <sup>1)</sup>	2.4	2.4	4.8	6	12	12	12	12	12					
Pressure ranges															
» LH-10 with PUR cable	bar <sup>1)</sup>	0.1	0.16	0.25	0.4	0.6	1	1.6	2.5	4	6	10	16	25	
Over pressure safety	bar <sup>1)</sup>	1	1.5	2	2	4	5	10	10	17	35	35	35	35	
Burst pressure	bar <sup>1)</sup>	2	2	2.4	2.4	4.8	6	12	12	20.5	42	42	42	42	
		1) 1 bar = 10.2 mH <sub>2</sub> O													

		LS-10					LH-10				
Materials											
■ Wetted parts		Stainless steel					Stainless steel {Hastelloy}				
» Pressure connection/diaphragm		Stainless steel					Stainless steel {Hastelloy}				
» Protection cap		PA					PA {Stainless steel} {Hastelloy}				
» Cable		PUR					PUR {FEP}				
Power supply UB	UB in VDC	10 ... 30					10 ... 30 (14 ... 30 with signal output 0 ... 10 V) (5 ... 30 with battery operation, signal output 0.5 ... 4.5 V)				
Signal output		4 ... 20 mA, 2-wire					4 ... 20 mA, 2-wire 0 ... 20 mA, 3-wire {0 ... 5 V, 3-wire} {0 ... 10 V, 3-wire} {0.5 ... 4.5 V, 3-wire, with battery operation, for pressure ranges 0 ... 0.25 bar} {Pt100, 4-wire; IEC 60751}				
Pt100	» only model LH-10										
■ I max	mA						3				
■ I mess	mA						1				
Max. load R <sub>A</sub>	R <sub>A</sub> in Ohm										
■ Current signal output	UB in VDC	R <sub>A</sub> ≤ (UB - 10 V) / 0.02 A - (cable length in m x 0.14 Ohm)									
■ Voltage signal output		-					R <sub>A</sub> > 100 k				
Insulation voltage	VDC	500 <sup>2)</sup>									
		<sup>2)</sup> NEC Class 02 power supply (low voltage and low current max. 100 VA even under fault conditions)									
Accuracy	% of span	≤ 0.25 (BFSL)					≤ 0.125 (BFSL)				
	% of span	≤ 0.5 <sup>3)</sup>					≤ 0.25 <sup>3)</sup>				
		<sup>3)</sup> Including non-linearity, hysteresis, zero point and full scale error (corresponds to error of measurement per IEC 61298-2)									
		Adjusted in vertical mounting position with lower pressure connection									
Non-linearity	% of span	≤ 0.2 (BFSL) according to IEC 61298-2									
Non-repeatability	% of span	≤ 0.1									
1-year stability	% of span	≤ 0.2 (at reference conditions)									
Permissible temperature of											
■ Medium <sup>4)</sup>		-10 ... +50 °C / +14 ... +122 °F									
		-					{-10...+85°C/+14...+185°F with FEPcable}				
■ Storage <sup>4)</sup>		-30 ... +80 °C / -22 ... +176 °F									
		<sup>4)</sup> Also complies with EN 50178, Tab. 7, Operation (C) 4K4H, Storage (D) 1K4, Transport (E) 2K3									
Rated temperature range		0 ... +50 °C / +32 ... +122 °F									
Temperature coefficients within rated temperature range											
■ Mean TC of zero	% of span	≤ 0.2 / 10 K (< 0.4 for pressure range ≤ 0.25 bar)									
■ Mean TC of range	% of span	≤ 0.2 / 10 K									
CE-conformity											
■ EMC directive		2004/108/EEC, EN 61 326 Emission (Group 1, Class B) and					Immunity (industrial locations)				
Wiring protection											
■ Short-circuit proofness		Sig+ towards UB-									

# Specifications

# Model LS-10 / LH-10

■ Reverse polarity protection		UB+ towards UB-	{Lightning protection EN 61000-4-5; 1.5J}
Weight			
» Level probe	kg	Approx. 0.18	Approx. 0.2
» Cable	kg/m	Approx. 0.08	
» Additional weight	kg	Approx. 0.5	

{ } Items in curved brackets are optional extras for additional price

## Dimensions in mm (100 mm = 3.937 inch)

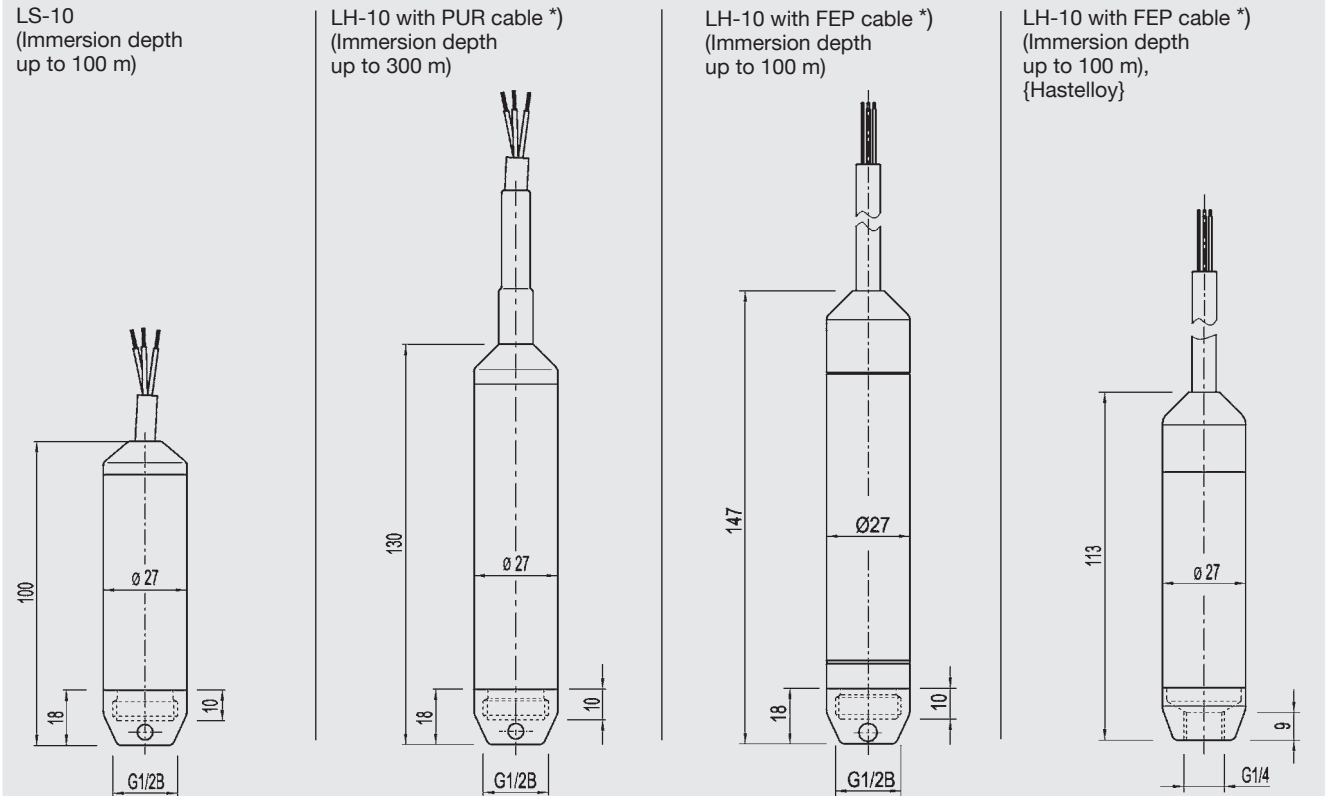

\*) FEP cable and lightning protection EN 61000-4-5; 1.5 J on request.

For mounting no additional strain relief required because the cable has a max. tensile strength of 1000 N (500 N with FEP cable).

For installation and safety instructions see the operating instructions for this product.

## Wiring details

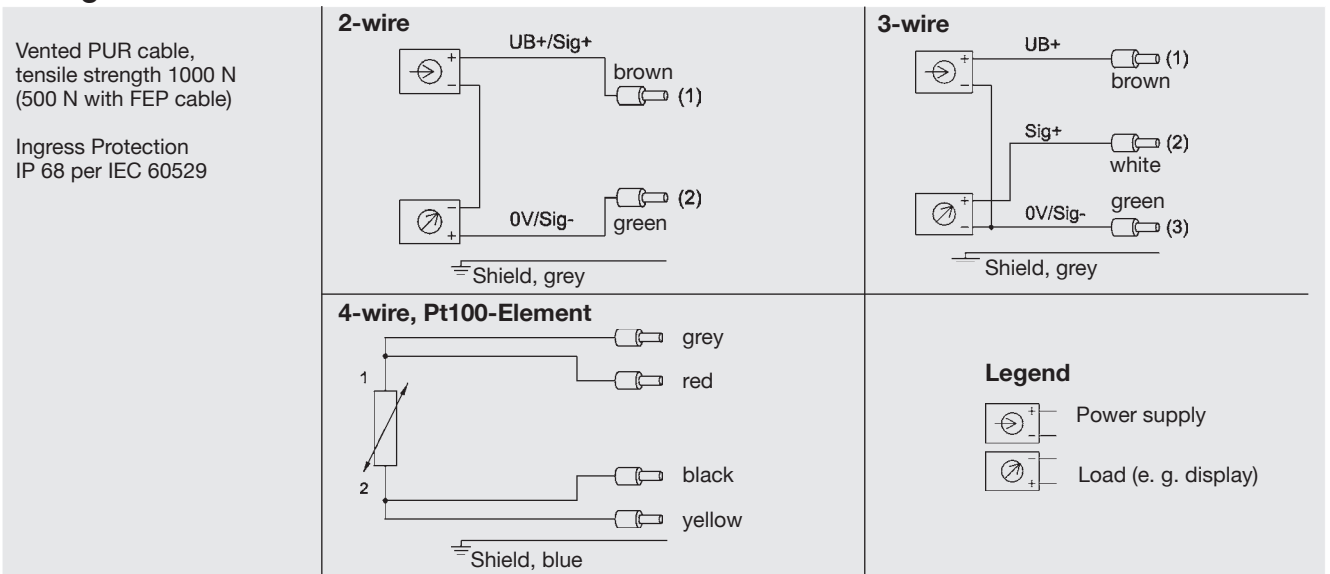

## Accessories (Dimensions in mm)

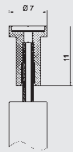
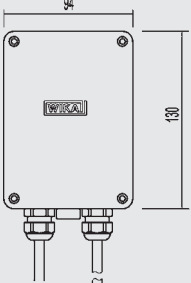
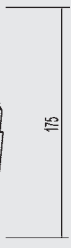
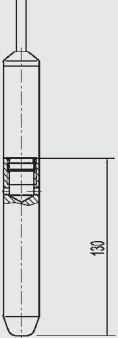
Bestell-Nr.		
	<p><b>71 93 131</b></p>	<p>The optional filter element for self-mounting avoids the ingress of pollution and water into the venting tube for the pressure compensation to the atmosphere.</p>
	<p><b>24 59 686</b></p>	<p>The optional cable box with weather protection IP 67 with venting element (NEMA 4) is suitable for mounting outside of the shafts and tanks or directly in dry control boxes.</p>
	<p><b>20 74 257</b></p>	<p>For mechanical assembly of the level probe a cable straining clamp is optionally available.</p>
	<p><b>15 24 399</b></p>	<p>In order to increase the mass of the level probe an additional weight (approx. 500 g = 1.1 lb.) can be screwed on.</p>

## Further information

You can obtain further information (data sheets, instructions, etc.) via our internet address [www.wika.de](http://www.wika.de)

Specifications and dimensions given in this leaflet represent the state of engineering at the time of printing. Modifications may take place and materials specified may be replaced by others without prior notice.



**WIKAI Alexander Wiegand SE & Co. KG**  
 Alexander-Wiegand-Straße 30  
 63911 Klingenberg/Germany  
 Tel. (+49) 9372/132-0  
 Fax (+49) 9372/132-406  
 E-mail [info@wika.de](mailto:info@wika.de)  
[www.wika.de](http://www.wika.de)